



# AMERICAN SPECIALTIES, INC.

441 Saw Mill River Road, Yonkers, NY 10701 (914) 476-9000

MODEL No: 8522

ISSUED: 1-87

REVISED: 9-04

## SURFACE MOUNTED ROLL PAPER TOWEL DISPENSER

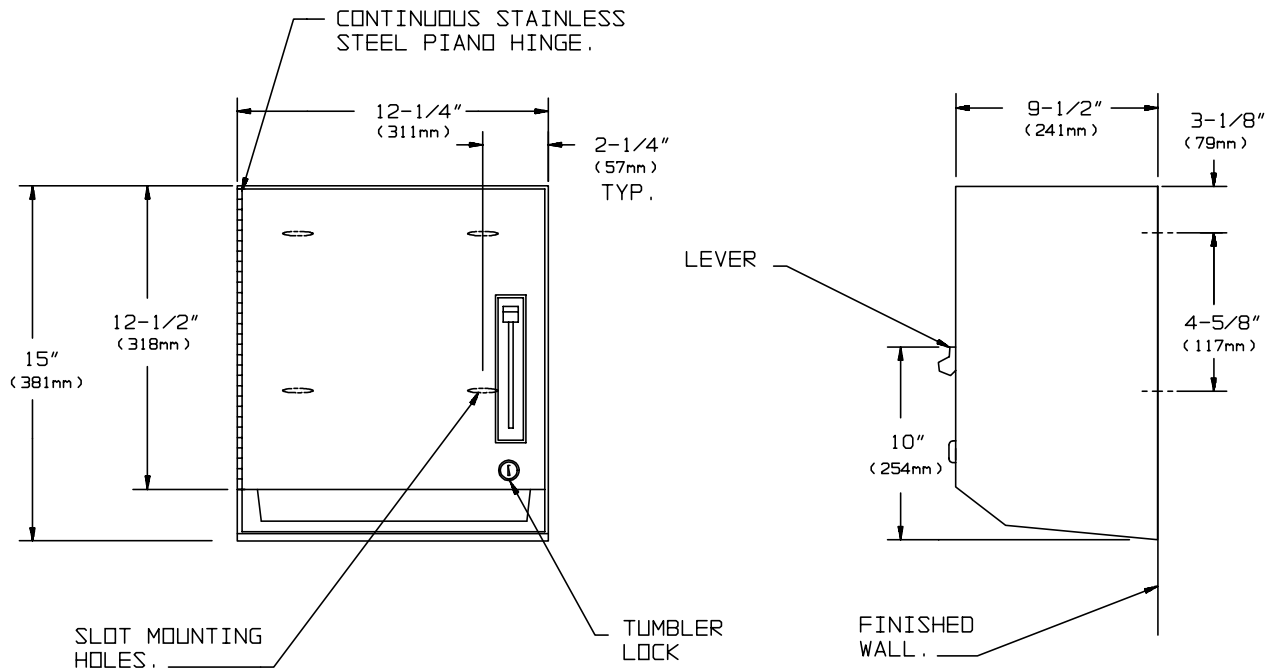

### SPECIFICATION

Surface Mounted Roll Paper Towel Dispenser shall hold and dispense one 8" or 9" (203mm or 229mm) wide up to 800 ft (244m) long standard towel roll and one stub roll up to 4" (102mm) dia. Automatic transfer mechanism shall dispense towels from stub roll before starting new roll. Lever shall operate unit and shall adjust to dispense 2-1/2", 4", or 5" (64mm, 102mm, and 127mm) preset length of towel. Unit frame and cabinet shall be fabricated of alloy 18-8 stainless steel, type 304, 22 gauge. Door shall be fabricated of 18 gauge. Towel dispensing slot shall be smooth and burr-free for snag-free dispensing and user safety. Roll paper towel mechanism shall be enamel painted steel. Door shall be attached to cabinet at side with a full length 3/16" (5mm) dia. multi-staked stainless steel piano hinge and shall be held closed with a tumbler lock keyed alike to other ASI washroom equipment. Structural assembly of all components shall be of welded construction. All exposed surfaces shall be N°4 satin finish and shall be protected during shipment with a PVC film easily removable after installation.

**Surfaced Mounted Roll Paper Towel Dispenser shall be Model N°8522 as manufactured by American Specialties, Inc., 441 Saw Mill River Road, Yonkers, New York 10701-4913**

### INSTALLATION

Unit is surface mounted to wall using N° 10 self tapping screws (by others) through concealed mounting holes provided. For compliance with ADA Accessibility Guidelines, unit should be installed so that towel dispenser lever is 54" (1372mm) maximum above finished floor (AFF) if clear floor side reach access is provided or 48" (1219mm) maximum AFF if clear floor forward reach access only is provided.

### OPERATION

Towels are fed by lever action until supply is depleted. Towel feed length is adjustable for economy by pin (supplied) limiting of lever stroke length. Unit may be reloaded with a full roll to automatically start when finished with an existing partial roll. Locking door prevents unauthorized access or removal.

Accessory Specialties

AMERICAN DISPENSER

Desert Ray Products

WATROUS inc.