



AMERICAN SPECIALTIES, INC.

441 Saw Mill River Road, Yonkers, NY 10701 (914) 476-9000

MODEL No: 0715

ISSUED: 1-87

REVISED: 4-98

SURFACE MOUNTED DUAL ROLL TOILET PAPER HOLDER

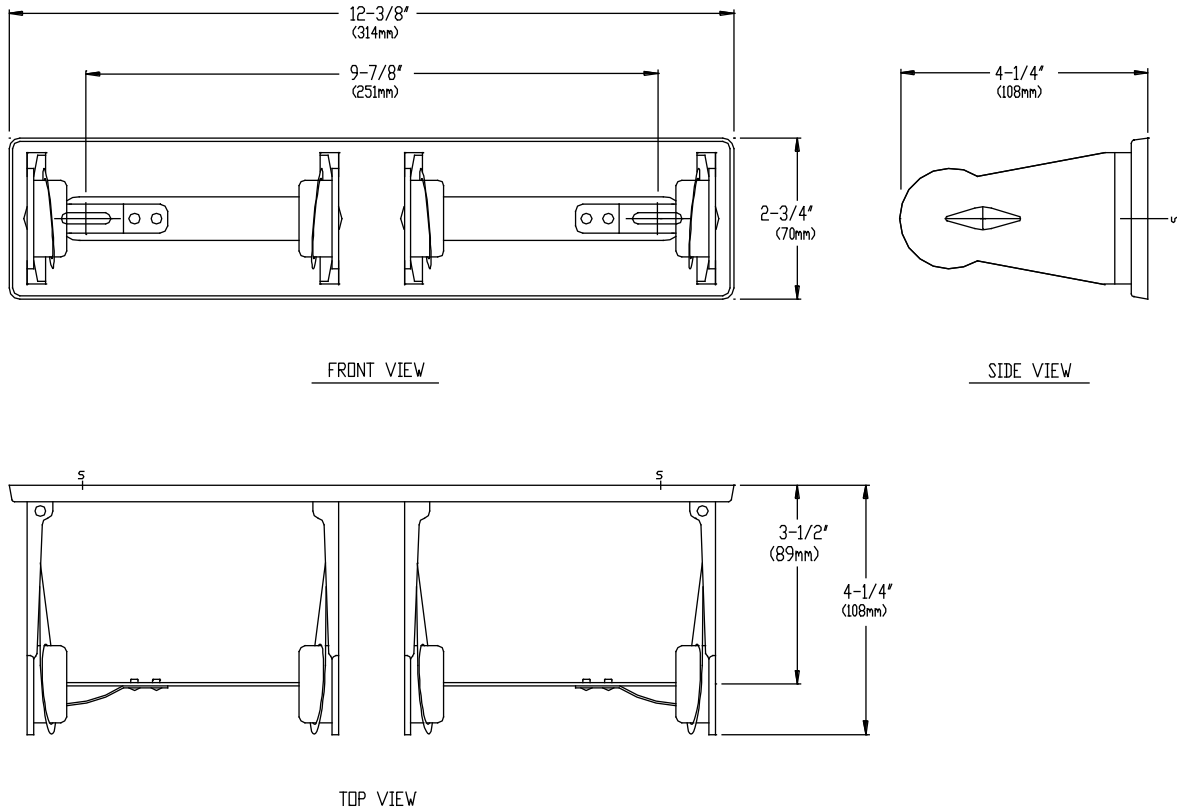

SPECIFICATION

Surface Mounted Dual Roll Toilet Paper Holder shall hold two (2) rolls of standard core size toilet tissue up to 5" (127mm) dia. Unit shall be fabricated of №18 gauge high polished chrome-plated steel. A brake-spring shall provide controlled delivery for each roll of toilet paper. Roll core prevents access to release-catch spring and roll shall be non-removable until roll is depleted.

Surface Mounted Dual Roll Toilet Paper Holder shall be Model №0715 of American Specialties, Inc., 441 Saw Mill River Road, Yonkers, New York 10701-4913.

INSTALLATION

For general utility, mount unit 32" (813mm) above finished floor (AFF) from center line of holder. Surface mount and secure holder to wall with two (2) №10 self-tapping screws (supplied) through mounting slots in back plate. For compliance with ADA Accessibility Guidelines, install unit so that center line of holder is 19" (483mm) minimum AFF to 44" (1118mm) maximum AFF.

OPERATION

Toilet paper is dispensed with controlled delivery from each roll. Roll is replaced on a cycle determined by maintenance needs. Roll cores prevent access to release catches and must be removed to allow end support arms to swing away for service roll replacements.

Accessory Specialties

AMERICAN DISPENSER

Desert Ray Products

WATROUS INC.