



AMERICAN SPECIALTIES, INC.

441 Saw Mill River Road, Yonkers, NY 10701 (914) 476-9000
www.americanspecialties.com

MODEL No: 7305-2

ISSUED: 1-87

REVISED: 1-06

TOILET PAPER HOLDER

Specify Finish Required → -B = Bright Stainless Steel
 -S = Satin #4 Stainless Steel

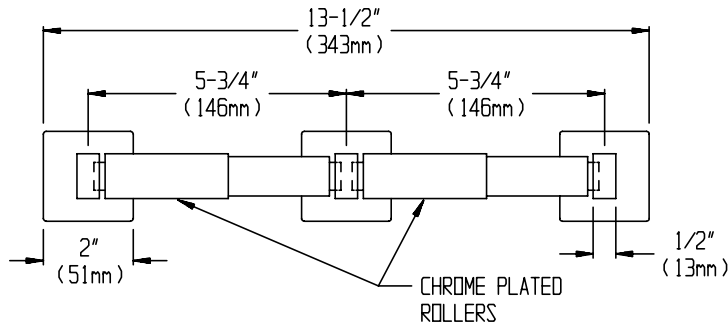

FRONT VIEW

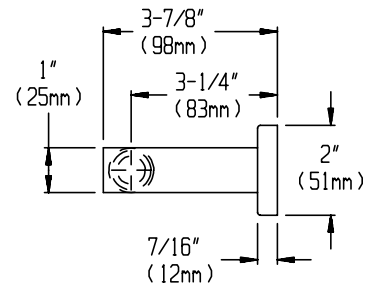

SIDE VIEW

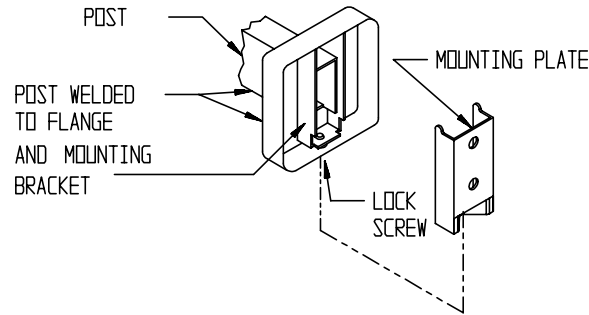

CONCEALED MOUNTING DETAIL

SPECIFICATION

Dual Roll Surface Mounted Toilet Paper Holder unit shall hold and dispense two (2) rolls of standard core roll tissue up to 5-1/2" (140mm) in diameter. Unit shall be fabricated of 18-8 stainless steel type 304. Mounting plates shall be included. Posts shall be fabricated of 1/2" x 1" (13mm x 25mm) rectangular tubes. Rollers shall be chrome-plated high impact-resistant ABS plastic and two (2) shall be supplied. All exposed surfaces shall be satin or bright finish.

Toilet Paper Holder shall be Model N° 7305-2S or N° 7305-2B of American Specialties, Inc., 441 Saw Mill River Road, Yonkers, New York 10701-4913

INSTALLATION

Attach mounting plates to wall using N° 10 self-tapping screws (by others). Attach each flange and post assembly to its mounting plate with set screw supplied. For compliance with ADA Accessibility Guidelines, install unit with centerline of rollers at 19" (483mm) minimum to 44" (1118mm) maximum above finished floor, and forward edge of roll no farther than 36" (914mm) from wall behind water closet fixture.

OPERATION

Spring loaded spindles revolve freely and hold rolls until cores are removed.